

DATA SHEET

S3000™ 1" ALUMINUM BLINDS

Product Features

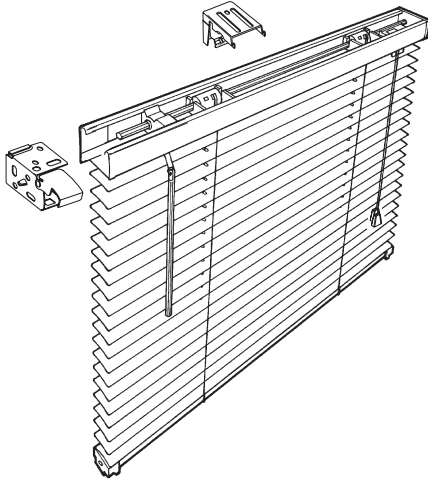

- Headrail with integrated valance and lightblocking lip
- Antistatic performance to repel dust
- Low HAP, low VOC paint process
- Snap-in hidden brackets
- Disengaging clutch
- Crash-proof cordlock
- Enclosed bottomrail
- GREENGUARD Gold certified
- Limited lifetime warranty



The SWFcontract product presented is identical to Bali® S3000™ 1" Aluminum Blinds.

Product Specifications

Headrail shall be 1" high x 1½" wide x .025" thick steel valance-free design with a curved front profile, rolled edges at the top and a lightblocking lip at the lower back side. The steel finishing process includes phosphate treatment for corrosion resistance, a chrome-free sealer, a low hazardous air pollutants (HAP) urethane primer, and a topcoat of low HAP, polyester-baked enamel.

Tilter shall be made of injection-molded thermoplastics for smooth low-friction operation and shall incorporate a clutch mechanism to prevent damage due to overtilting.

Tilt rod shall be electro-zinc coated solid steel measuring ¼" square.

Tilt wand shall be clear polycarbonate with a hexagonal cross section measuring approximately ¼" diameter and attached to the tilter shaft by means of a spring clip for easy removal.

Cordlock shall be a snap-in design made of durable high-impact nylon with a stainless steel wear guard incorporating a floating shaft-type locking pin. The design provides a crash-proof safety feature that will lock the blinds automatically upon release of the lift cord.

Drum and cradles shall be low-friction thermoplastic and provided for each ladder.

Installation brackets shall be top loading, zinc-plated steel with a snap-in design for easy installation.

Braided ladder shall be made of 100% polyester yarn, incorporating two extra-strength rungs per ladder for slat support. Standard ladder spacing shall be 21.5mm.

Slats shall be 5000 series cold-rolled aluminum containing the maximum allowable recycled content to produce a high-strength and corrosion-resistant flexible product. Slats shall be nominally 1" wide x .006" thick and processed to provide a smooth, hard, less porous surface with antistatic performance to repel dust. Slats shall be treated with a topcoat of polyester-baked enamel.

Bottomrail shall be a completely enclosed tubular shape made of phosphate-treated steel for corrosion resistance and finished with a chrome-free sealer, low HAP urethane primer, and a topcoat of low HAP, polyester-baked enamel. Bottomrail shall measure .025" thick.

Options:

- .008" thick slat
- Inverted slat for daylighting
- 20mm ladder spacing
- Perforated slat
- Hidden Holes™ privacy and lightblocking slat with 18mm spacing
- Tilt limiter
- Ring tilter
- ½" slat width (S4000 Micro Blind)
- Top-lock cordlock
- Ring pull
- Box brackets
- Extension brackets
- Hold down brackets
- Cut-outs
- Cordless lift (uses 1½" high x 2⅞" wide headrail)