

DATA SHEET

HERITAGE® 2" ALUMINUM BLINDS

Product Features

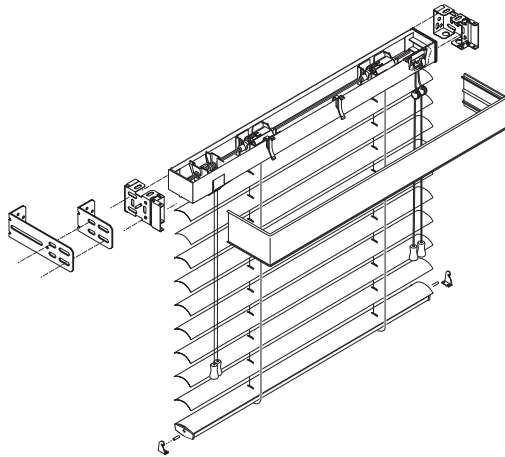

- SureTight® Headrail system
- Antistatic performance to repel dust
- Low HAP, low VOC paint process
- Enclosed bottomrail
- Box bracket
- Cord tilt
- GREENGUARD Gold certified
- Limited lifetime warranty

Product Specifications

SureTight Headrail shall be 1⁵/₈" high x 2¹/₄" wide x .022" thick U-shaped steel with 1/₈" lightblocking lip on the bottom center line. The steel finishing process includes phosphate treatment for corrosion resistance, a chrome-free sealer, a low HAP urethane primer, and a topcoat of low HAP, polyester-baked enamel.

Cord tilter shall be a snap-in component incorporating a worm and pulley of low-friction thermoplastic and a nylon gear. Standard tilt cords shall measure 1.8mm diameter.

Tilt rod shall be electro-zinc coated solid steel measuring 1/4" square.

Cordlock shall be metal of a snap-in design incorporating a floating, shaft-type locking pin and shall incorporate a crash-proof safety feature that will lock blind automatically upon release of cord.

Drums shall be made of high-strength thermoplastic, which securely anchors braided ladders.

Installation brackets shall be made of phosphate-treated steel with a urethane primer and polyester-baked enamel finish to match headrail. The design shall incorporate a hinged front cover.

Braided ladder shall be made of 100% polyester yarn, incorporating two extra-strength rungs per ladder for slat support. Standard ladder spacing shall be 44mm.

Slats shall be 5000 series cold-rolled aluminum containing the maximum allowable recycled content to produce a high-strength and corrosion-resistant flexible product. Slats shall be nominally 2" wide x .008" thick and processed to provide a smooth, hard, less porous surface with antistatic performance to repel dust. Slats shall be treated with a topcoat of polyester-baked enamel.

Bottomrail shall be C-shaped 9/16" high x 2" wide x 0.40 thick anodized aluminum. It shall be fully enclosed with a dust cover slat and finished with a polyester-baked enamel to match headrail.

Options:

- 1" or 1¹/₂" cloth tapes
- Inverted slat for daylighting
- Wand tilt
- Ring tilt
- Ring pull
- Extension brackets
- Hold down brackets
- Cut-outs
- Deluxe valance
- Motorized – tilt only



The SWFcontract product presented is identical to Bali® Heritage® 2" Aluminum Blinds.